

Step #1 Attach the aluminum clamp to the clamp adapter using the 4 - M6 Bolts

- a. **M6 x 100mm bolts (4)** for the Router Clamp
- b. Make sure the slot on both clamps is facing left (shown in image below)

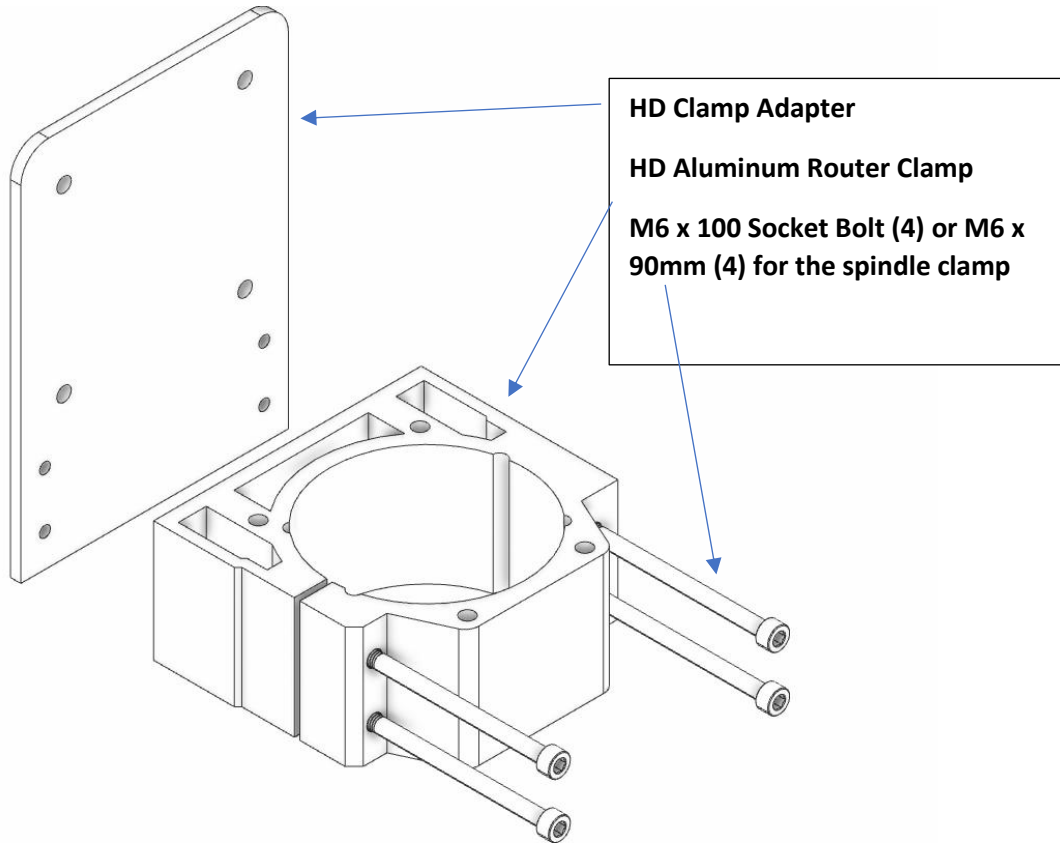

Step #2 Attach the **Acorn Nuts (4)** to the exposed end of the bolts. These are for aesthetics only and are non-functional.

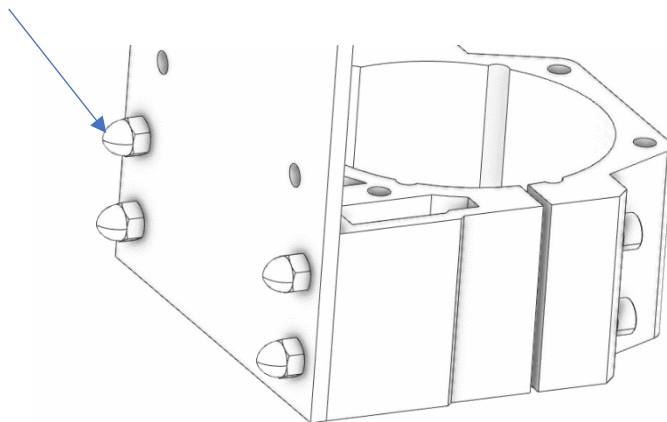

Step #3 Remove the 4 bolts attaching your machine's current router or spindle cradle to the aluminum back plate

Step #4 Attach the assembled clamp adapter using the provided Torx head 27- ¼ /20 bolts provided

